

PART I-OVERVIEW

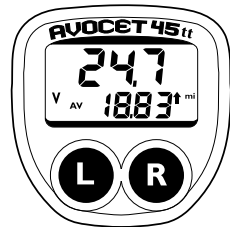

PRESSING LEFT BUTTON

Selects speed and distance functions
Starts and stops timer and changes setup data



PRESSING RIGHT BUTTON

Moves between speed, distance and time
Moves from one setup function to the next



HOLDING LEFT BUTTON

Reaches Gear-Inch and Riding Time
In Setup reaches Distance Setup

HOLDING RIGHT BUTTON

Reaches clock set from the time function



PRESSING BOTH BUTTONS

Resets functions individually



HOLDING BOTH BUTTONS

Resets all functions except Total Distance
Reaches setup

FUNCTIONS

1a



SPEED
Maximum Speed

1b



SPEED
Average Speed

1c OPTIONAL



SPEED
Cadence

1d OPTIONAL



GEAR INCH
Cadence

Cadence and Gear-Inch functions are optional and require the cadence mount kit

2a



TRIP DISTANCE
Total Distance

2b



DESTINATION TIME
Destination Distance

3a



TIMER
Clock

3b



RIDING TIME
Riding Distance



ENERGY SAVER

Cyclometer displays the Clock after 1-2 hours of inactivity

INDIVIDUAL RESET. Press both buttons to reset the displayed function.

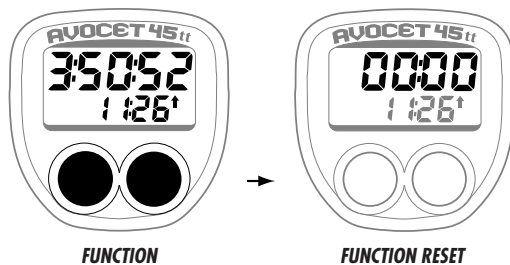

GLOBAL RESET. To reset all functions except Total Distance, hold both buttons about 5 seconds and release when the test pattern appears.

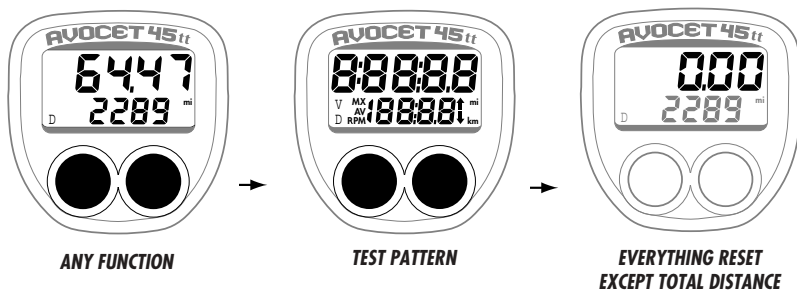

PART II-FUNCTIONS

SPEED (V). Current speed is displayed to 400.0 mph or km/h in 0.1 increments. Low speeds are displayed down to 1 mph. The Cyclometer uses speed data to calculate distance, and in mountain biking, good low-speed sensitivity ensures that distance will not be lost during low speed climbing or while walking unridable trails. Speed data is on-line and not clipped or averaged. The speed display is updated every second. With immediate, high-precision speed you can gauge your performance and smoothness clearly.



MAXIMUM SPEED (MX). Maximum speeds of up to 400.0 mph or km/h are recorded with 0.1 resolution. Reset individually by pressing both buttons when maximum speed is displayed. If you are only interested in the maximum speed reached on a ride, do a global reset at the beginning, and check your maximum at the end. Reset before a descent or a sprint to find your maximum speed for that particular part of your ride. Maximum speed is an important performance indicator in sprint training, and you can track your progress if you reset before each effort, then check the maximum afterward.





AVERAGE SPEED (AV). Average speeds of up to 199.99 mph or km/h are displayed with 0.01 mph resolution. Reset individually by pressing both buttons when average speed is displayed. Usually you will want to know average speed for an entire ride. For training, you may want to reset often to reset the Riding Time/Riding Distance function or to check performance on specific sections of a ride.

With 0.01 resolution you will immediately see the results of speed variations on your average. If you measure your performance by average speed on a course you regularly ride, the Cyclometer 45tt will show your progress precisely. To make riding on wind trainers and rollers more interesting and effective, you can design increasing-tempo and steady-tempo workouts.

PaceArrow™. The PaceArrow, displayed in all functions when the bicycle is moving, indicates whether current speed is above or below average speed. For training, the PaceArrow is most effective on a rolling route. To keep the arrow pointing up, you will have to work hard on the uphill, then use the downhill for recovery. You can adjust the difficulty of the workout by resetting Average Speed more or less often. The PaceArrow and Average Speed make unforgiving taskmasters for those who like hard training.

Auto Start/Stop. The Cyclometer 45tt displays true average speed. It only averages when the bicycle is moving. Its ride timer calculates average speed independent of the stopwatch timer. Time stopped at traffic lights or rest stops on long rides such as centuries will not reduce your average speed.



CADENCE (RPM). OPTIONAL: REQUIRES CADENCE MOUNT KIT. Cadence, the rate of pedaling, is displayed from 15 to 250 crank rpm. Cadences below 15 rpm display as 0. When you start pedaling, no cadence will be displayed for 4 seconds, and when you stop pedaling, a rate will remain for 4 seconds.

Most coaches recommend that cyclists learn to ride smoothly while 'spinning.' Although cadence varies with speed, terrain, and riding style, many riders tend to let cadence fall when they are inattentive. Checking cadence will prompt you to keep your pedaling steady.

GEAR-INCH. OPTIONAL: REQUIRES CADENCE MOUNT KIT. To reach Gear-Inch, hold down the left button when Cadence is displayed. Gear-Inch is the traditional American and British system for representing gear size. It equals the number of teeth on the chainwheel divided by the number of teeth on the freewheel cog multiplied by the diameter of the tire. Gear-Inch will tell you if one chainwheel-cog combination produces a gear larger, smaller, or equal to another. You can see whether you have duplicate gears, and you can establish a logical shifting sequence.

When you enter the Gear-Inch function, or change gears, the upper display shows 5 dashes. In 4-6 seconds the whole gear number shows with a dash after the decimal point. 10 to 12 pedal strokes later, data will be available to show the complete gear-inch number in tenths. Coasting, even brief lapses in pedaling, resets Gear-Inch. **NOTE: THE GEAR-INCH FUNCTION WILL NOT OPERATE AND WILL DISPLAY 'ERROR' WHEN DESTINATION DISTANCE IS COUNTING DOWN.**

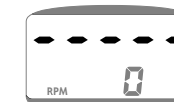



TRIP DISTANCE (D). Trip distances up to 199.99 miles are displayed with 0.01 resolution and from 200.0 to 1999.9 with 0.1 resolution. The display freezes when it reaches 1,999.9 miles. Reset individually by pressing both buttons when trip distance is displayed.

Most riders measure trip distance for an entire ride and zero the display with a global reset before they start riding. The high resolution of the Cyclometer 45tt's Trip Distance display, and the Cyclometer's excellent low-speed sensitivity give extremely accurate trip distances—but only if the unit is calibrated precisely with an accurately measured tire circumference. See setup instructions for the method for accurately measuring circumference. Use the Cyclometer 45tt's Trip Distance function to follow a route slip or to create a route slip for a tour with exact distances to turns and landmarks. In racing, Trip Distance will tell you how far you are into the course.



TOTAL DISTANCE (D). Whole miles up to 19,999 are displayed. After accumulating 19,999 miles the display freezes. Reset or adjust in Total Distance Setup. To record yearly mileage, reset before your first ride of a new year.

If you have accumulated over 12,500 miles total distance, then change your Cyclometer to display kilometers, you will exceed the display capacity of 19,999. However this distance will be retained and will be displayed again upon returning to miles.

DESTINATION DISTANCE/TIME. Press the left button in the Trip/Total Distance function to reach Destination Distance. Destination distances of up to 199.99 miles can be entered into the Cyclometer 45tt and will begin to count down when the function is turned on by pressing the left button. When the function is turned on, the “D” and the colons in the time display flash. After distance reaches zero, negative distance accumulates to -9.99 mi. At -9.99 the function resets to zero and turns off. The upper display shows the time during which the destination distance has been counting down.

ENTERING DESTINATION DISTANCE. In the destination distance function hold down the left button until the lower right digit flashes (3 seconds). Enter hundredths of a mile by pressing the left button. Press the right button to go to tenths of a mile, whole miles, and tens of miles. You can also enter 100 miles, but note that no number flashes until you press the left button to enter 1 in the hundreds position. If you don't enter a 1 in the hundreds position, you must press the right button twice to complete your entry. When the entry is complete the lower screen flashes once to confirm.

USING DESTINATION DISTANCE. In a time trial, you can enter the course distance in advance, then activate the function at the start line. Timing does not begin until the wheel turns. The relationship between remaining distance and elapsed time is constantly displayed so you can apportion your effort. At the finish, lock in the time and distance by pressing the left button. On any touring or training ride you can enter the distance to a town, landmark, or ride's end from a map, road sign, or from data collected by your Cyclometer.





TIMER. The Timer displays times to 9:59:59 then rolls over to 0 and continues timing. Press the left button to start and stop the Timer. Reset by pressing both buttons or by global reset. Reset also stops the Timer. You can time parts of your ride without affecting the average speed of the entire ride, because Average Speed is calculated from Riding Time that has its own timer.

CLOCK. The Clock can be set up in either 12 or 24 hour format. The colon between the hours and minutes in the Clock flashes to distinguish it from the Timer.

RIDING TIME AND RIDING DISTANCE. To reach riding time, hold down the left button when the timer is displayed. The Riding Time function shows the time and distance that have been used to compute average speed. Dividing the Riding Distance by Riding Time gives your average speed. Resetting Average Speed resets Riding Time and Riding Distance. By resetting Average Speed during a ride, you can use this function to split out time and distance for a part of a ride. Riding time only accumulates when the wheel is turning. Before an event with a standing start, you can reset Average Speed and timing will begin automatically when the wheel turns. Also, with time and distance displayed together, you can easily ride to a schedule. For example, if you set a goal of two hours for 40 miles, Riding Time will show you how much ahead of schedule or behind schedule you are as you progress through the ride.

PART III-SETUP

MILES OR KILOMETERS. To reach setup hold both buttons for 8 seconds until 'mi' or 'km' appears. Press the left button to switch between miles and kilometers. Stored speed and distance data are automatically converted to the units chosen. After selecting units, press the right button to go to calibration.

You can change from miles to kilometers for a specific ride such as a 40 km time trial or for a trip to a country where the metric system is used. Your accumulated miles will be converted and not lost. You can also change during a ride to see how fast you are going in km/h and how many kilometers you have travelled. To change, hold both buttons in any function until 'mi' shows. Press the left button to show 'km', then press the right button until you have exited setup.

When the Cyclometer displays kilometers, the Gear-Inch function becomes Development in centimeters. Development is the distance traveled by the bicycle with each revolution of the crank and is the European standard for expressing gear size.

Step 1



Step 1a



TOTAL DISTANCE SETUP. If you want to adjust total distance, hold the left button when 'mi' or 'km' is displayed. Total distance appears. Adjust the blinking digit with the left button, then go to the next digit with the right button. After adjusting all digits, exit to calibration with the right button.

When you install a new battery, accumulated total distance is lost. You can reenter this distance and you can also transfer distance from another computer by adjusting the total distance accumulated on your Cyclometer 45tt.

If you want to use the Total Distance function as a second Trip Distance function, you can adjust total distance to zero at the beginning of a week, month, or multi-day tour to record weekly, monthly, or tour miles.

Step 2



CALIBRATION. Find the calibration number that matches your tire size from the table, or measure tire circumference by the precise calibration method. Calibration by the table will give acceptable precision for speed, but if you want to take advantage of your Cyclometer 45tt's ability to measure distance with precision to 0.01 mile, you must measure your tire circumference.

When the arrow at the lower right of the display points up, pressing the left button increases the calibration number. When it points down, the number decreases. Holding the left button increments rapidly through the numbers. At the correct number, press the right button to go to sleep setup.

Precise Calibration. To take full advantage of the precision of your Cyclometer 45tt, measure the tire's 'rolling circumference' by the following method: Mark the ground under the valve stem when the stem is at its lowest point. Get on the bicycle and have a helper push you in your normal riding position until the valve stem returns to its lowest point. Take care that the tire travels in a straight line. Mark below the stem again, then measure the distance in inches between the marks. This measurement is your calibration number. Tire pressure can have a big effect on your measurement, so be sure to inflate your tires to your usual riding pressure. Recording the measurements for different bicycles and wheels below will save you the trouble of remeasuring in the future.

Bike/Wheel _____ Calibration #: _____

Bike/Wheel _____ Calibration #: _____

Calibration Table. Tire sizes are molded into tire sidewalls. This table is based on popular tire brands and assumes recommended inflation pressure and a rider weight of 165 lbs. (75 kg). Rear tires carry more weight than front, and this makes them smaller. If you use a rear mount, subtract .35" or 9 mm from the numbers below. There are many variables that affect tire size, so the table numbers are only approximate. To account for your unique combination of weight, tire pressure, and tire model, measure your tire circumference.

Tire Size	Calibration Number		Tire Size	Calibration Number		Tire Size	Calibration Number	
	Miles	Km		Miles	Km		Miles	Km
20 x 1.75	60.16 in	1528	26 x 1.95/2.0	80.51	2045	700 x 28	82.52	2096
24 x 1	69.02	1753	26 x 2.1	80.95	2056	700 x 32	83.31	2116
600 tubular	69.25	1759	26 x 1 3/8	81.42	2068	700 x 38	85.00	2159
650 tubular	75.95	1929	700 tubular	82.13	2083	27 x 7/8	81.77	2077
26 x 1	75.32	1913	700 x 20	81.93	2081	27 x 1	82.91	2105
26 x 1.25	76.89	1952	700 x 23	82.17	2087	27 x 1 1/8	83.58	2123
26 x 1.5	78.19	1986	700 x 25	82.32	2091	27 x 1 1/4	84.33	2142

Step 3



Step 4



CADENCE SELECT. All Cyclometer 45tt's are capable of displaying cadence. However, you must have a cadence mount if you want to use the cadence function. If your Cyclometer package is marked 'Gear/Cadence' you have the cadence mount. If you don't have a cadence mount, you can purchase it separately.

When 'RPM' appears, press the left button to activate Cadence. 'CAAd' shows indicating that Cadence is activated. If you activate Cadence, and you don't have a cadence mount, no reading will display in the Cadence function.

SLEEP. Ignore this step and press the right button to go to clock setup. Later, if you don't intend to use the Cyclometer for more than two months, return to setup. Advance to step 4 when 'SLEEP' is displayed and stop. The screen will go blank in 1 to 2 hours and power consumption will be reduced up to 50%. To activate the Cyclometer, press the right button and complete setup.

CLOCK SETUP. The display shows '12 hr' indicating that the clock will display in 12 hour format. Press the left button to change to 24 hour format. Press the right button to exit to clock set.

SET CLOCK HOUR. The hour digits blink. Advance them by pressing the left button. At the correct hour press the right button.

SET CLOCK MINUTE. The minute digits blink. Advance them rapidly by holding the left button, or one at a time by pressing the left button. At the correct minute, exit setup by pressing the right button.

Step 5



Step 6



Step 7



Instrument displays either miles or kilometers. Functions can be reset individually or globally

Speed Functions

SPEED: To 400.0 mph in 0.1 mph increments
Maximum speed: To 400.0 mph in 0.1 increments (resettable)
Average Speed: To 199.99 mph in 0.01 increments. Calculated only while the wheel is turning. Averages up to 250 hours (resettable)
Pace Arrow: Indicates whether current speed is above or below average speed. Displayed in all functions
Cadence: From 15 to 250 rpm. Requires cadence mount kit included in packages marked 'Gear/Cadence'; available separately for others
Gear-Inch: From 20 to 200. Requires cadence mount kit

Distance Functions

TRIP DISTANCE: To 999.99 mi in 0.01 mi increments and from 1,000.0 to 1,999.9 in 0.1 increments (resettable). Display freezes at 1999.9 mi
Total Distance: To 19,999 mi in 1 mi increments. Display freezes at 19,999 mi
Riding Distance: To 999.99 mi in 0.01 mi increments and from 1,000.0 to 1,999.9 in 0.1 increments (distance used to compute average speed)
Destination Distance: Distances up to 199.99 mi can be entered and count down after the function is turned on
Time Functions
TIMER: To 9:59:59 in 1 second increments
Clock: To 1 minute; 12 or 24 hour format
Riding Time: To 9:59:59 (time used to compute average speed)
Destination Time: To 9:59:59. Only accumulates when Destination Distance is turned on and the wheel is turning

Setup functions

Miles/Kilometers: Stored data converted when setup is changed.
Displays gear development in cm when setup for km
Total Distance Setup: Total distance programmable by the user
Wheel Size Calibration: Calibration for wheels from 30.24" circumference to 130.99" circumference in 0.04" increments
Sleep: Cuts power consumption by 50% while retaining stored data

Dimensions: 1.75" X 1.75" x 0.3"

Weight: Unit, 0.5 oz

Display: Dual liquid crystal, UPPER NUMBERS 0.3" high; lower numbers 0.2 high

Operational Temperature Range: 0°F to 150°F

Data: Speed display updated every second. MultiPulse transmitter sends 20 pulses per wheel revolution

Weather resistance: Water resistant

Mount System: Compatible with all Avocet computers except models 15 and 25

Battery: 1.5 volt, 2 year life. Use Avocet Cyclometer 45 battery or 357 (Renata, Eveready, RayOVac, Phillips), SR44W (Maxell, National, Panasonic, Sony, Toshiba), D357H (Duracell).

Accessories:

Cadence mount kit to add gear/cadence (if your package is marked 'Gear/Cadence', you already have this kit)
 Rear mount kit for use with trainers that keep the front wheel stationary

PART IV-INSTALLATION-GEAR/CADENCE

1. TRANSMITTER. Remove the rear wheel. Place the transmitter on the hub flange with its magnet facing out. Thread a cable tie through every third slot on the transmitter if your wheel has 32 spokes (4 ties) and every fourth slot if it has 36 spokes (3 ties). Attach the ties to spoke crossings. Center the ring while gradually tightening the ties. Trim the tie ends and reinstall the wheel.

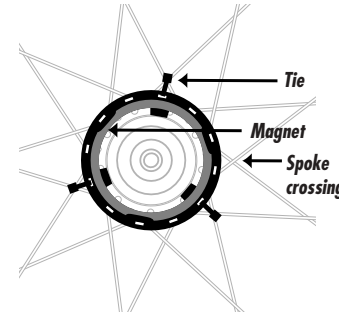

2. RECEIVER. Insert two cable ties in the slots on the receiver holder. Place the holder on the inside of the seat stay or chain stay and align the receiver with the transmitter. Tighten the ties and trim their ends. Slide the receiver in its holder until it nearly touches the transmitter.

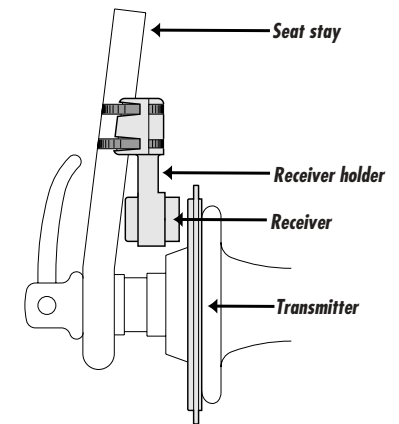

3. CADENCE MAGNET AND PICKUP. Attach the cadence magnet with a cable tie on the inside of the left crank arm about 3 inches from the pedal. Align the crank with the left chainstay and mount the pickup on the bottom of the left chainstay opposite the magnet. Run the wide tie through the slot in the pickup and wrap its loosely around the chainstay. To position the pickup, slide it backward or forward on the chainstay until its alignment notch is opposite the alignment ridge on the magnet. Then rotate the pickup upward until the gap between the magnet and pickup is 1.5 mm to 5 mm. After aligning the pickup, pull the tie tight and trim its end.

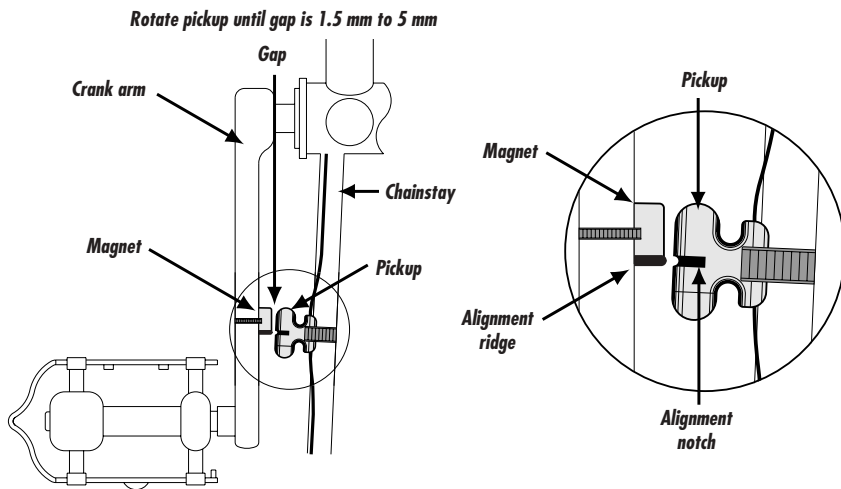

3. RECEIVER AND CADENCE WIRES. Attach the receiver wire to the inside of the chainstay with ties gathering any excess under one of the ties. Run the cadence wire from under the bottom bracket shell and up the underside of the down tube. Secure the wire with ties, then run it up the brake cable wrapping excess wire around the cable. Leave enough slack in the wire between the frame and the brake cable that the handlebars turn all the way in both directions. Install the mount on the handlebars as described on page 22.

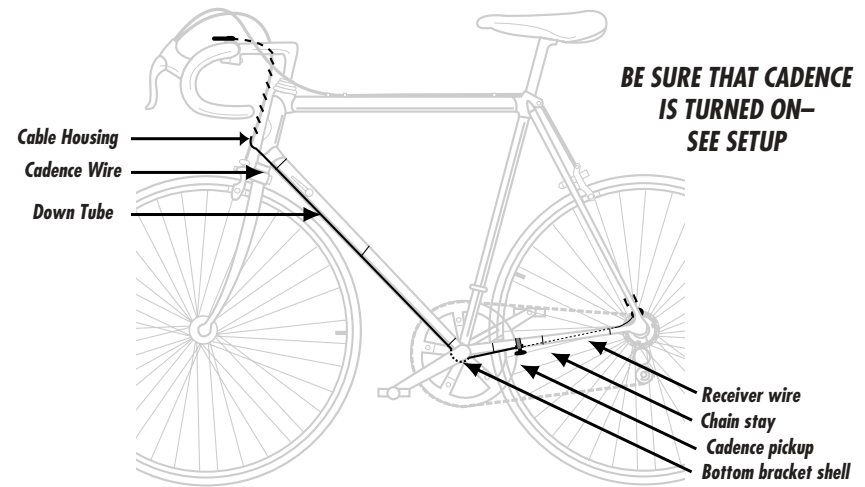

PART V-INSTALLATION-FRONT MOUNT

1. TRANSMITTER. Remove the front wheel. Count the number of spokes in the wheel. Use the 4-prong transmitter for 32-spoke wheels, and the 3-prong transmitter for 36 or 28-spoke wheels. If necessary remove the magnet and metal ring from one housing and move it to the other. Keep the strong side of the magnet facing out as originally installed. The transmitter snaps on the flange of a standard, low-flange hub. After attaching the transmitter reinstall the wheel. You can also attach the front transmitter with ties if your hub flange is too large or small for it to snap on. Cut off the transmitter prongs with scissors, then attach it to the spoke crossings.

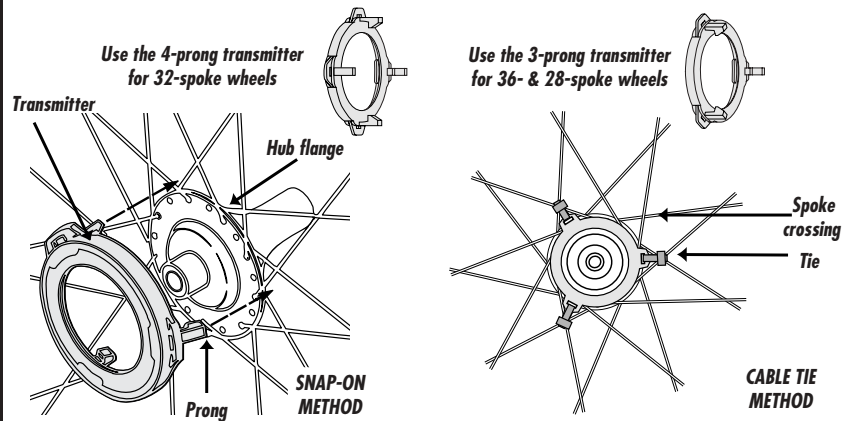

2a. MOUNTAIN RECEIVER. Fits any fork. If you have a suspension fork or a mountain bike fork with fat blades that taper for the slotted ends, use the mountain receiver. Clean and dry the front of the right fork blade. Slide the receiver into its holder (wires on the inside). Loosen the pivot screw and install the fork pad loosely on the front of the right fork blade with two cable ties inserted through the holes in the pad. Pivot and rotate the receiver until it touches the transmitter magnet. Tighten the pivot screw with the receiver against the front of the fork. Tighten and trim the cable ties, and fine-tune the adjustment by sliding the receiver in its holder until it nearly touches the transmitter.

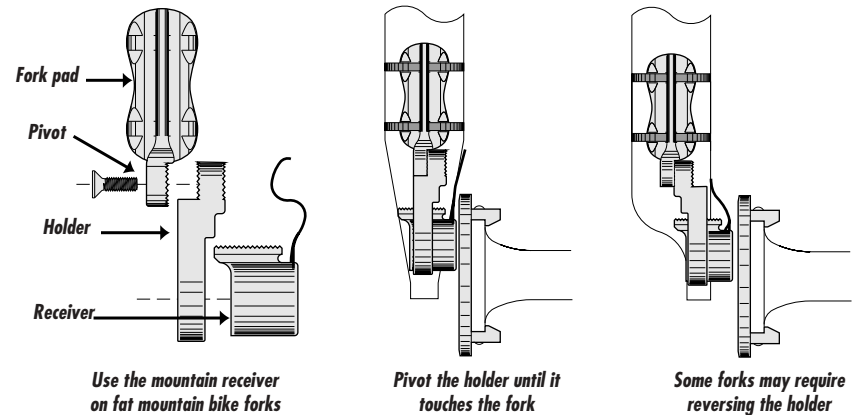

2b. ROAD RECEIVER. For standard road forks. Position the receiver on the front of the right fork blade opposite the transmitter magnet (black stripe in illustration). The side of the receiver with the wires coming out of it should be next to the magnet. Thread a cable tie through the hole in the receiver holder and around the fork. Pull the cable tie tight. Position the receiver so that it is as close as possible to the transmitter by rotating the holder on the fork and by sliding its toothed adjuster in or out.

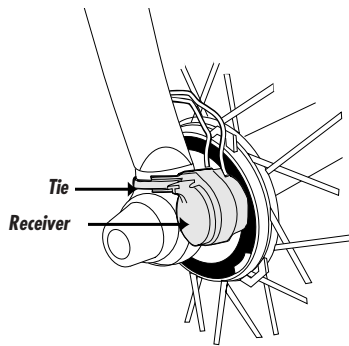

3. RECEIVER WIRE. Secure the wire with ties or tape starting at the receiver. Attach the wire only to parts that rotate when the bicycle is steered—the fork, the handlebar stem, or the front brake cable. Do not attach the wire to the head tube. Wrap excess wire around the front brake cable.

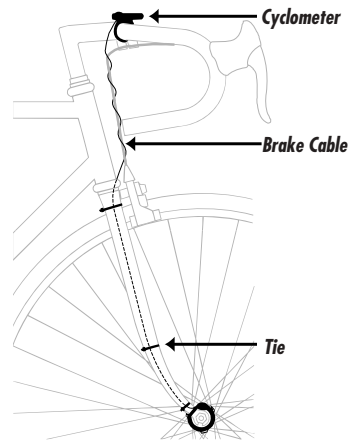

MOUNT BRACKET. Remove the clamp screw and place the mount bracket on the handlebar near the right side of the stem. Insert the clamp screw and tighten it until the bracket does not move when the Cyclometer is inserted or removed. If the handlebar is too small for the clamp, put the shim provided under the clamp for a tight fit.

MOUNTING THE UNIT. Slide the Cyclometer into the mount bracket from front to rear until it snaps on. Choose the speed function, then spin the front wheel and watch for a reading. If the display remains at zero make sure that the receiver and transmitter are aligned and nearly touching.

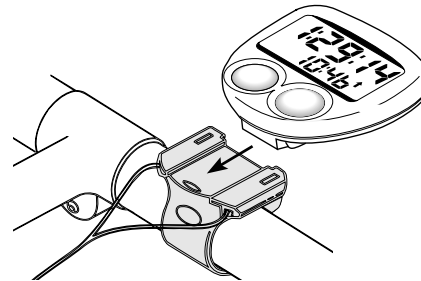

INSTALLING A NEW BATTERY. To remove the battery, pry up the cap on the back of the Cyclometer with a screwdriver. Install the new battery with its positive (+) side toward the cap, then press in the cap with your thumb. Use only an Avocet Cyclometer 45 battery or equivalent (see specifications). Removing the battery erases setup data and total distance. After installing a battery, the unit goes into setup ready for entry of setup data. At this time total distance can be programmed into the Cyclometer.

