

Monster  
T

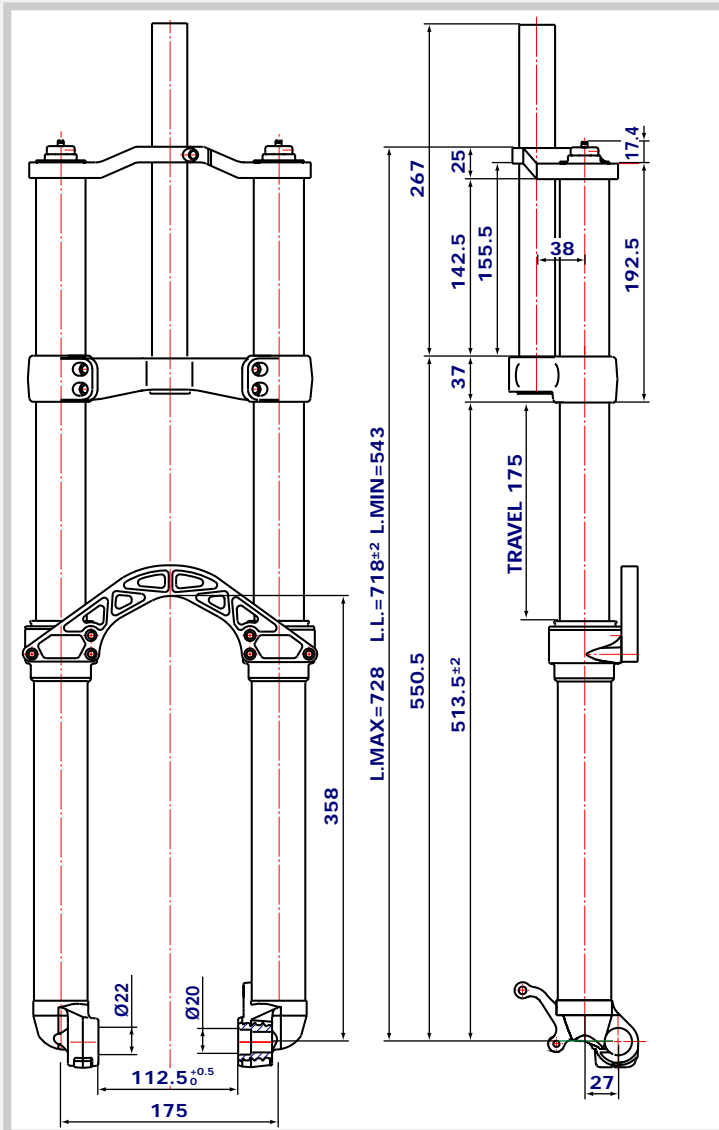

## GENERAL

- The double plate fork is specifically designed for Downhill use. Damped by hydraulic cartridges and sprung by a mechanical coil spring system.
- Rebound damping cartridge inside each fork leg.
- Spring pre-load and rebound damping adjustment controlled via external top mount adjusters.
- Stanchion tube secured to the crown and upper crown. The system gives the fork unmatched structural strength.
- Parts subjected to friction are cooled and lubricated by specially formulated oil.
- Left slider comes with brake caliper adapter.
- Axle support is the same drop-out design as in motorbikes, with shaft threaded.
- Wheel shaft (20 mm diam.) available on request.
- Adapter kit for 3" wheel installation available on request.

**Steer tube:** EASTON aluminum steer tubes available for 1 1/8" x267 mm, threadless.

**Crown:** Forged and CNC-machined "BAM" aluminum alloy.

**Upper crown:** CNC-machined aluminum alloy. Two versions available for different frame sizes.

**Arch:** CNC-machined aluminum.

**Stanchions:** Anodized EASTON aluminum with variable butting, diam. 40 mm.

**Springs:** with constant pitch.

**Sliders:** Forged and CNC-machined aluminum alloy

**Slider bushing:** 2 in each fork leg, composed of a copper base and impregnated with an anti-friction coating.

**Seals:** Computer designed oil seals guarantee the highest quality seals available.

**Oil:** Specially formulated oil which eliminates foaming and viscosity breakdown while providing complete stiction-free performance.

**Fork leg oil:** 380 cc, type EBH 16- SAE 7.5.

## INSTRUCTIONS

### GENERAL RULES

1. Where specified, assemble and disassemble the shock absorption system using **MARZOCCHI** special tools only.
2. On reassembling the suspension system, always use new seals.
3. If two screws are close one to the other, always tighten using a 1-2-1 sequence. In short, screw the first screw just up to the point it is well tightened, then tighten the second screw and then go back to the first one and screw it tighter.
4. Clean all metal parts with a special, preferably biodegradable solvent, such as trichloroethane or trichloroethylene.
5. Before reassembling, lubricate all parts in contact with each other using silicone fat spray or a specific oil for oil seals.
6. Always grease the conic seal rings before reassembling.
7. Use wrenches with metric size only. Wrenches with inch size might damage the fastening devices even when their size is similar to that of the wrenches in metric size.

Monster

T

## **FAILURES, CAUSES AND REMEDIES**

*This paragraph reports some troubles that may occur when using the fork. It also indicates possible causes and suggests a remedy. Always refer to this table before doing any repair work.*

### **FAILURES**

### **CAUSES**

### **REMEDIES**

*Excessive oil build up on stanchions*

- 1. Oil seal is worn out*
- 2. Stanchion tube is scored*
- 3. Excessive dirt on slider oil seal*

- 1. Replace oil seal*
- 2. Replace stanchion tube, oil seal and dust seal*
- 3. Clean the oil seal seat and replace oil seal*

*Oil leaking through the bottom of slider*

*O-ring seal on the cartridge nut is damaged*

*Replace the O-ring seal*

*Fork has not been used for some time and is locked out*

*Oil seals and dust seals tend to stick to stanchion tube*

*Raise dust seal and lubricate stanchion tube, oil seal and dust seal*

*Fork rebounds too fast even though the adjuster is set to hardest damping position*

*Cartridge is faulty*

*Replace hydraulic cartridge*

*Excessive play of stanchions into the sliders*

*Main slider bushings are worn*

*Replace main slider bushings*

*Adjuster position does not affect fork operation*

*Dirt inside legs*

*Clean carefully and change oil*

## RECOMMENDATIONS FOR MAINTENANCE

**MARZOCCHI** forks are based on advanced technology, supported by year-long experience in the field of professional mountain biking. In order to achieve best results, we recommend to check and clean the area below the dust seal and the stanchion tube after each use and lubricate with silicone oil.

In general, **MARZOCCHI** forks can offer top performance from the start. However, in some cases a short running-in period is required (5-10 hours) for inner adjustments. This running-in period will make fork life longer and ensure fork top performance over time.

**IMPORTANT:** change oil at least every 100 working hours.

## INSTALLATION

Installing the fork on a bicycle is a very delicate operation that should be carried out with extreme care.

A threadless steer tube is pre-installed on the fork from the factory. It will need to be cut to the required length for a proper fit. Always have the installation checked at one of our Technical Service Centers.

**⚠ WARNING:** "A-Head Set" headset/steer tube mounting and adjustment must be carried out in compliance with the headset manufacturer's instructions. Improper installation may jeopardize the safety of the rider.

After any installation always check for the following:

- proper torque of bolts fastening stanchion tube onto lower crown and upper crown;
- proper torque of bolts fastening brake arch onto slider
- proper torque of bolts fastening shaft to drop out

To replace it, contact one of our Technical Service Centers with the required tools.

**⚠ WARNING:** In case of improper installation of the steer tube into the crown, the rider might lose control of his/her bicycle, thus jeopardizing his/her safety.

## MOUNTING THE FORK ON THE FRAME

### FIG. A

Remove the upper crown (28) from steer tube and fork legs by loosening the fastening screws (29) and (31).

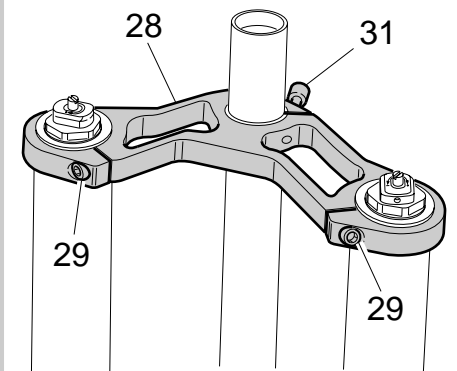

**FIG. B**

Assemble the fork to the frame complete with headset. Fit the upper crown (28) into the upper stanchions and the steer tube.

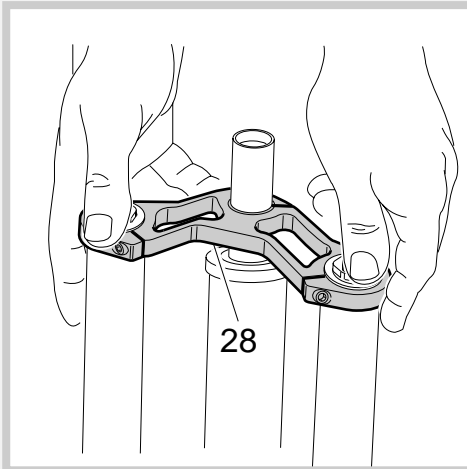

**FIG. C**

The stanchions edge (13) must be aligned with or slightly lower than the upper crown (28). If fork legs overprotrude, fit some spacers (C) to the plate close to the steer tube.

In case of frame with higher steer tube, use the optional plate supplied on request.

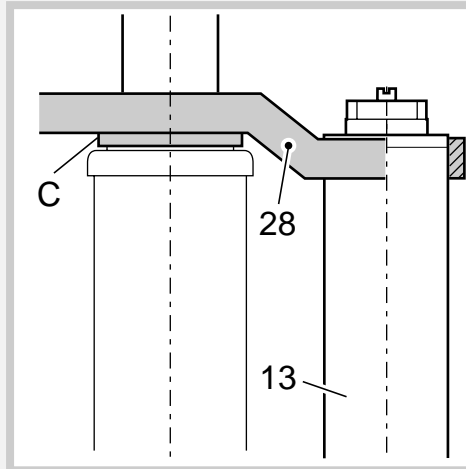

**FIG. D**

Fit the handlebar support and the "A-Head Set" cap over the upper crown (28) and then adjust the steering. Now finally tighten the screws (29) and (31) on the upper crown to 11 Nm.

**⚠ WARNING:** Loosen the screws (29) and (31) on the upper crown before adjusting the steering. Tighten the above bolts to the required torque when finished.

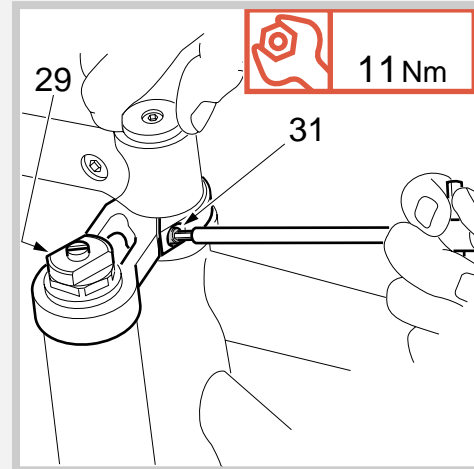
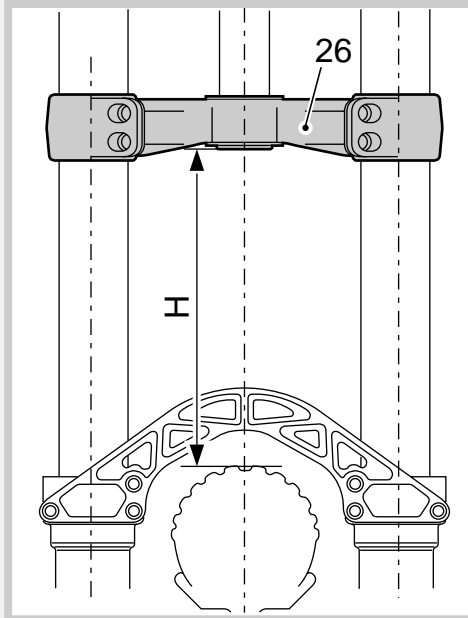

**FIG. E**

If the crown (26) position with respect to the stanchions (13) has been changed for any reason, adjust the original distance.

- Distance "H" between crown and tyre edge (when inflated) should not be lower than total travel (175 mm) + 3 mm.

**⚠ WARNING:** If lower Crown is improperly matched with stanchions, it may touch the tyre and cause severe injuries to the rider.



**FIG. F**

Tighten the 4 stanchions fastening screws (27) onto the crown to 11 Nm.

**⚠ WARNING:** do not overtighten the screws holding the stanchions to the crown as this may distort the stanchions and weaken the whole structure.

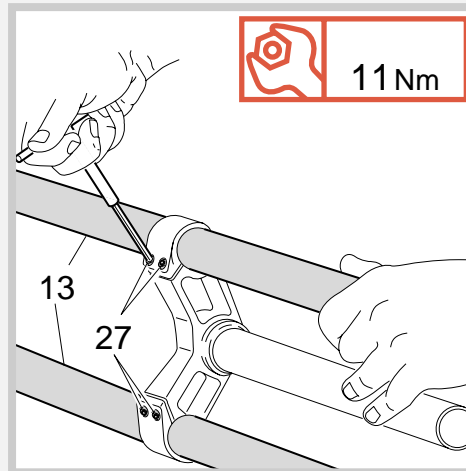

## FRONT WHEEL FIXING

**IMPORTANT:** for a safe and proper performance of this fork and all related devices, the front wheel should be absolutely secured as specified in the instructions given below.

### FIG. G

Insert the complete wheel assembly between the sliders and fit the wheel shaft (23) into the slider that accommodates the wheel shaft pinch bolt (29) from the right hand side.  
Rotate wheel shaft clockwise to start it into the LH slider.

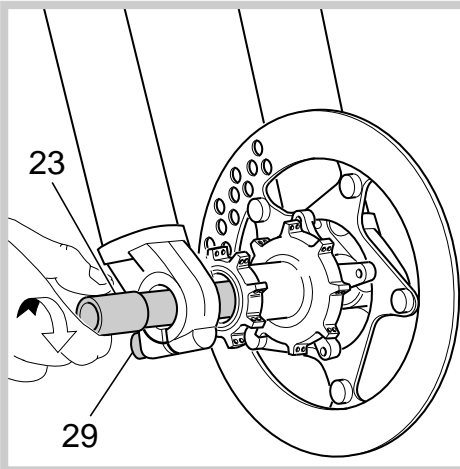

### FIG. H

Tighten the wheel shaft (23) counter clockwise from the opposite end with a 8-mm Allen wrench. Tighten to 20 Nm.

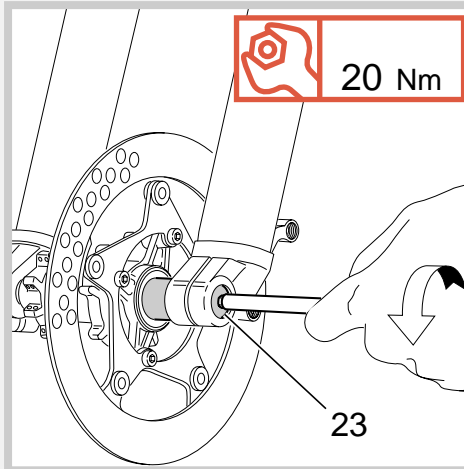

### FIG. I

Compress the fork several times so the sliders will become properly seated onto the wheel shaft. Lock the pinch bolt (29) on the r.h. lug to 6 Nm.

### DISASSEMBLY

To remove the wheel proceed as follows:

- loosen the bolt (29) on the r.h. drop-out;
- screw the wheel shaft (23) clockwise onto the l.h. drop-out (see FIG. H);
- remove the shaft (23) from the opposite side (see FIG. G).

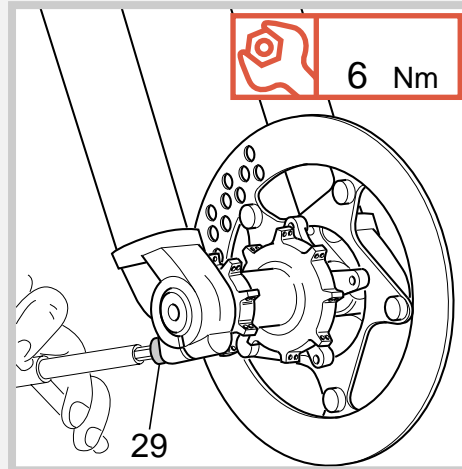

### DISC BRAKE SYSTEM ASSEMBLY

Assembling the brake caliper onto the slider is a very delicate operation that should be carried out with extreme care. Improper assembly might overstress the caliper supports, which might break. This system should be assembled by specialized technicians in a position to fully understand and properly follow the instructions given by the manufacturer.

### FORK CONFIGURATION FOR 3" WHEEL INSTALLATION

(Fig. L)

Before you can install a 3" wheel, you will need to:

- replace standard arch with oversized arch (38). Reuse the fastening bolts (25).
- Fit the spacers (36) to hydraulic cartridges ends (11) and (35).
- Replace the standard foot nuts with the special nuts (37).



**WARNING:** Unless fork is properly configured as detailed above, tyre will touch the arch when a 3" wheel is installed.

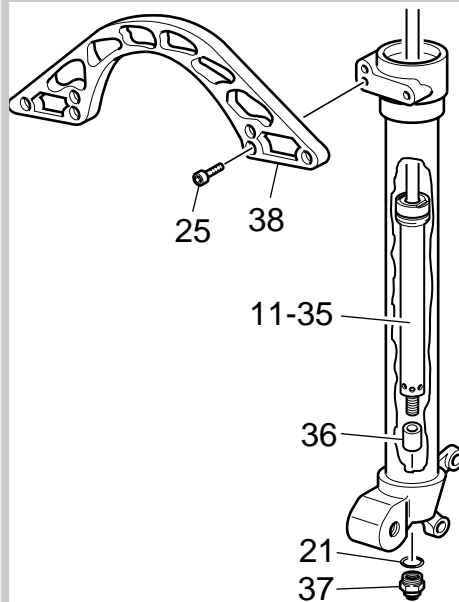

## ADJUSTMENTS

### SPRING PRELOAD

The spring preload for COMPRESSION damping can be adjusted by turning the knob **(2)** on top of fork legs. From the factory the fork is set at minimum preload, i.e. the adjustment knob completely unscrewed counterclockwise. However, springs are slightly preloaded to help counteract static loads during COMPRESSION. By turning the adjustment knob clockwise, the preload is increased up to the maximum value equal to 15 mm of spring preload. This adjustment is essential in order to have the right fork response for the rider's weight and riding style.

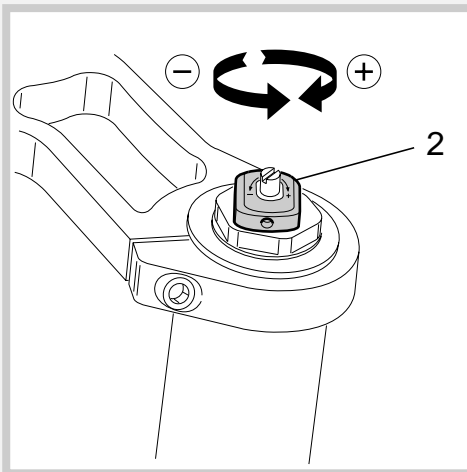

### REBOUND DAMPING ADJUSTMENT

Fork legs feature an adjuster **(E)** for REBOUND DAMPING adjustment. Turning this adjuster clockwise into the cartridge rod, changes the hydraulic setting of the inner valves. In short, the amount of adjustment applied on the piston in the fluid determines the rate of compression rebound damping.

To adjust, always start from the minimum damping setting, i.e. unscrew completely counterclockwise. About 8 turns - abt. 4 mm of the adjustment - are possible.

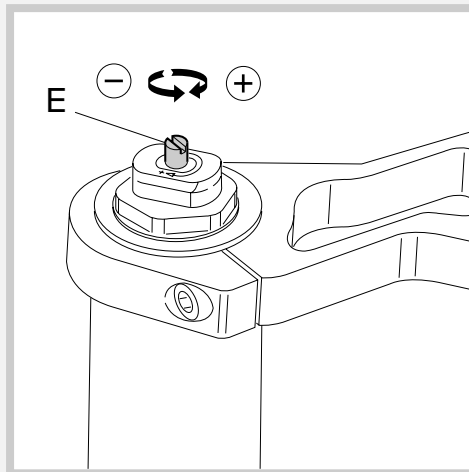

## DISASSEMBLY

### GENERAL

- The reference numbers given in this section relate to the components shown in the forks exploded view.
- These operations refer to the fork legs having already been removed from the crown and disassembled from the brake arch.
- Before starting any operation, please read the diagram below. It shows the quickest procedure and the exact sequence in which it should be disassembled. Start from the part first to be disassembled and then follow the arrows to remove the remaining parts.

### DISASSEMBLY DIAGRAM

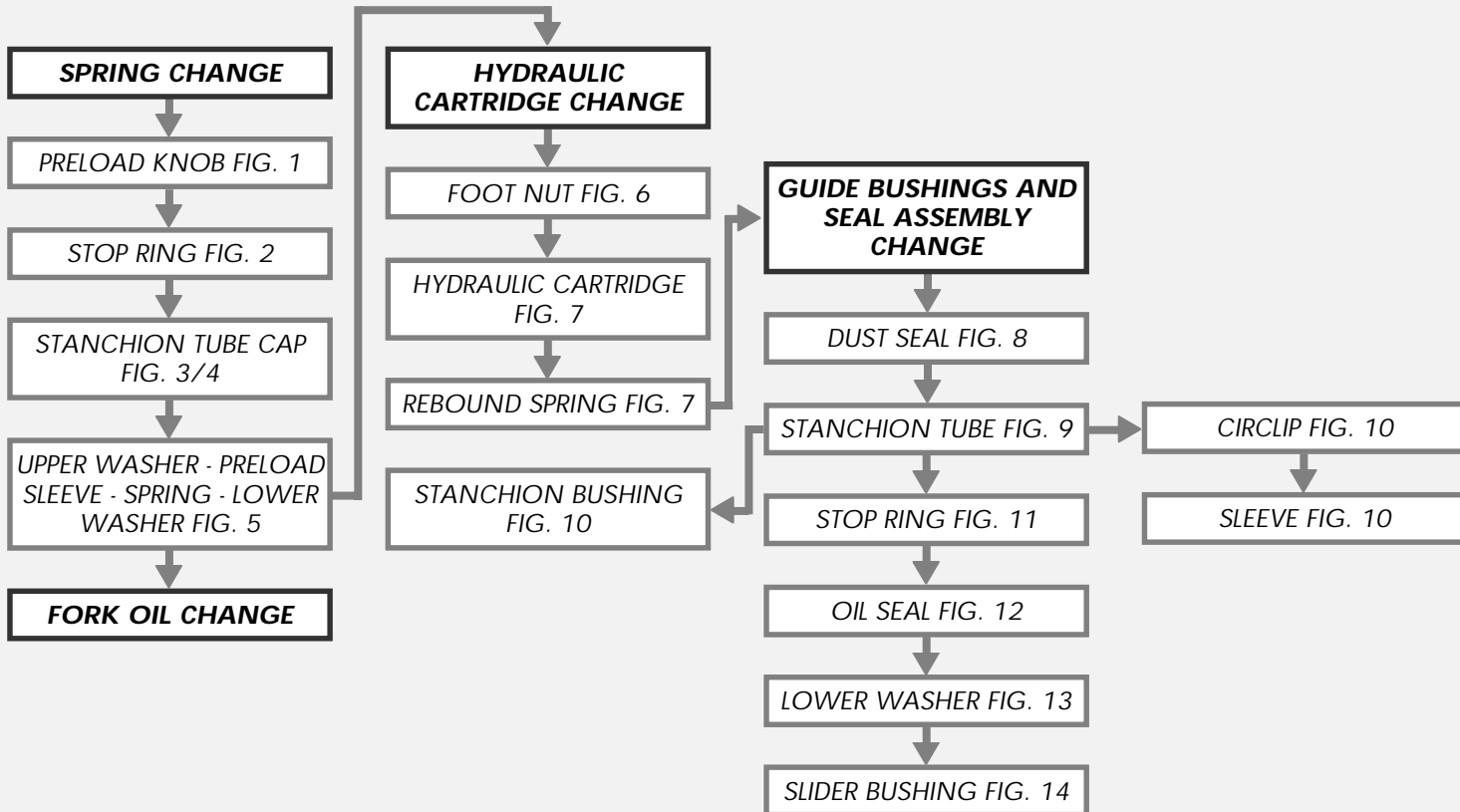

### SPRING CHANGE

**FIG. 1**

Set knob (2) to minimum preload value. Loosen the grub screw (3) fastening the preload knob (2) by means of a 1.5 mm Allen wrench. Remove grub screw from cap assembly.

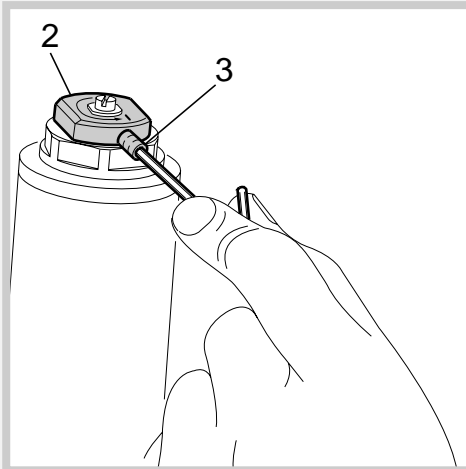

**FIG. 2**

Remove the stop ring (4) from the top of the preload knob support with a small screwdriver.

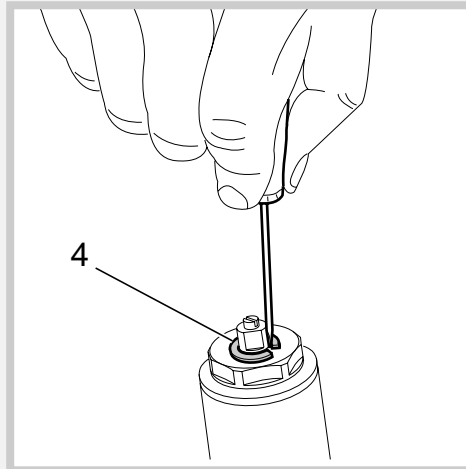

**FIG. 3**

Place the stanchion tube in a vice. Be sure not to damage or dent it in the process. Unscrew the cap (5) complete with O-ring (6) with a 26 mm end wrench.

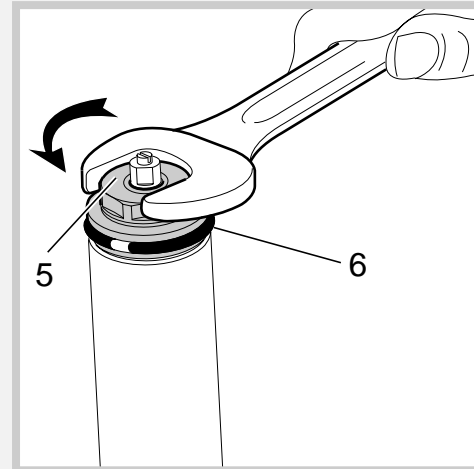

**FIG. 4**

Position the plunger (7, see exploded view), into the cap, to the minimum preload value.  
Push down the stanchion tube.  
Lock the check nut (11) and remove the cap (5) from hydraulic cartridge top.

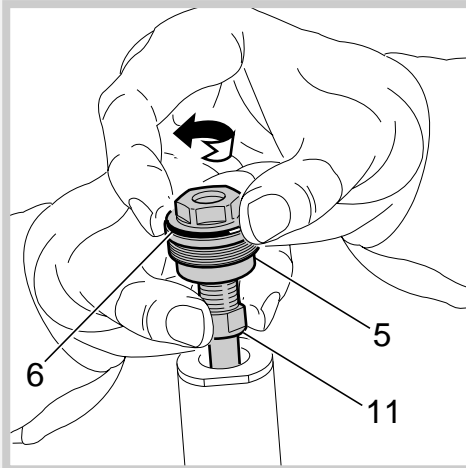

**FIG. 5**

Remove the upper washer (8), the preload sleeve (1) and the spring (9).  
Let all the oil drain into the fork leg. By following this procedure, there is no need to check the oil level. Make all necessary changes.

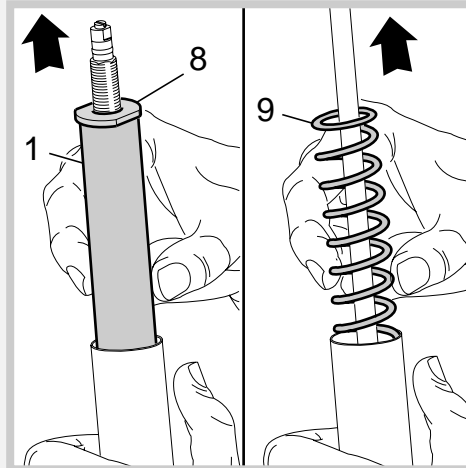

**HYDRAULIC CARTRIDGE CHANGE**

**FIG. 6**

Let all the oil drain out.



**WARNING:** Remember to always recycle any used oil.

To change the fork leg oil follow the procedure as described in REASSEMBLY from FIG. 24 to FIG. 29.

Turn the fork leg upside-down and unscrew the foot nut (22) complete with O-ring (21) by the use of a 15 mm socket wrench.

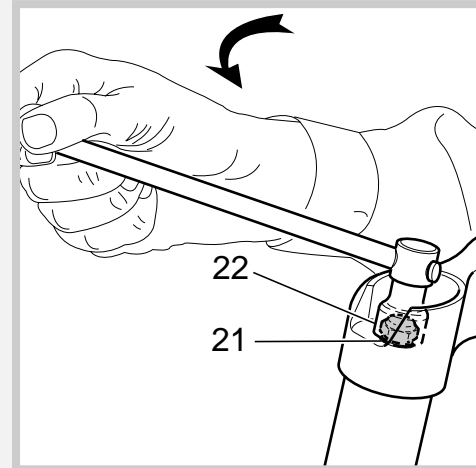

**FIG. 7**

Pull the hydraulic cartridge (11) complete with lower washer (8A) and rebound spring (12) out of the stanchion tube. Replace the whole hydraulic cartridge.

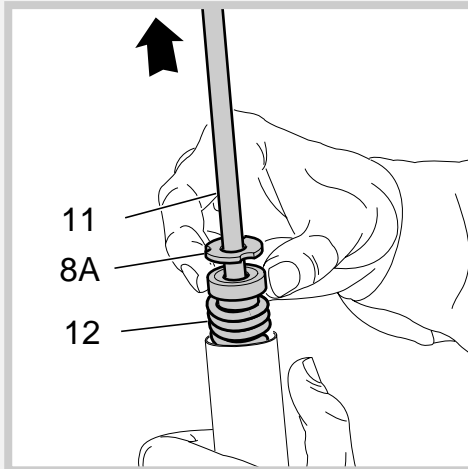

**GUIDE BUSHINGS AND SEAL ASSEMBLY CHANGE**

**FIG. 8**

Use a small screwdriver and remove the dust seal (14) from the top of the slider. Pull the dust seal out of the stanchion tube.

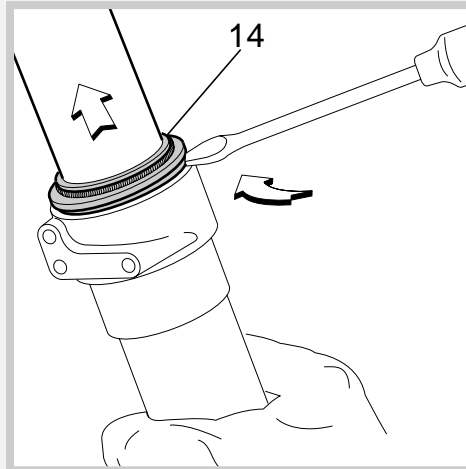

**FIG. 9**

Pull the stanchion tube (13) completely out of the slider. Pull strongly to overcome the resistance of the guide bushing of the stanchion tube to slide through the slider bushing.

**IMPORTANT:** the seal unit will be permanently damaged by the guide bushing. Always change the oil seals after the above procedure.

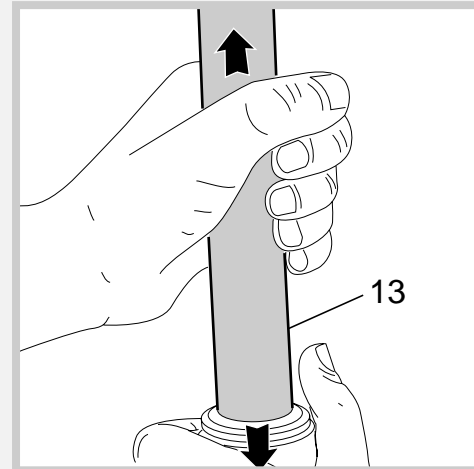

**FIG. 10**

A sleeve (33) is located inside the stanchion tube. Remove the outer snap ring (32) to remove the sleeve (33). Should the guide bushing (34) be damaged, remove it from the stanchion (13) inserting a small screwdriver into the bushing slot.

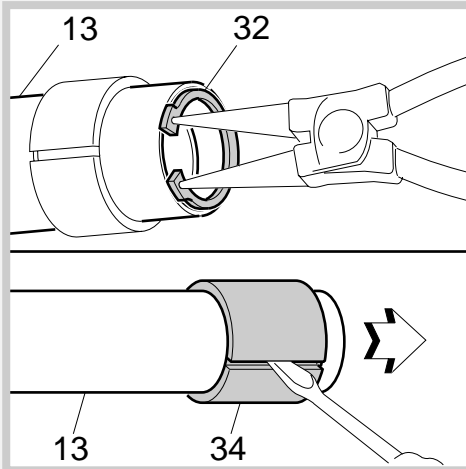

**FIG. 11**

Remove the stop ring (15) from the slider by placing the screwdriver bit in one of the three openings on the stop ring and carefully lifting the ring out of place.

**IMPORTANT:** when removing the stop ring, make sure not to damage its seat.

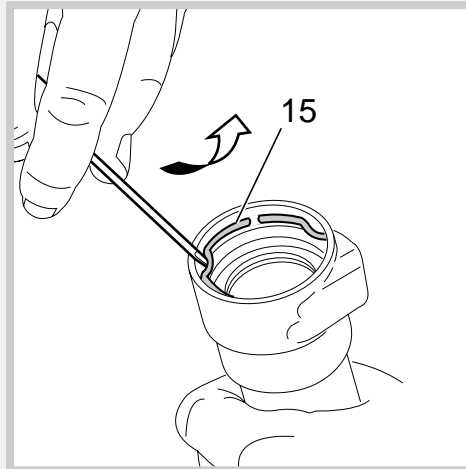

**FIG. 12**

Fit the slider protector (A) onto the slider and remove the oil seal (16) with the help of a large slot screwdriver.

**IMPORTANT:** when removing the oil seal, make sure not to damage its seat. Once removed, the oil seals should not be used again.

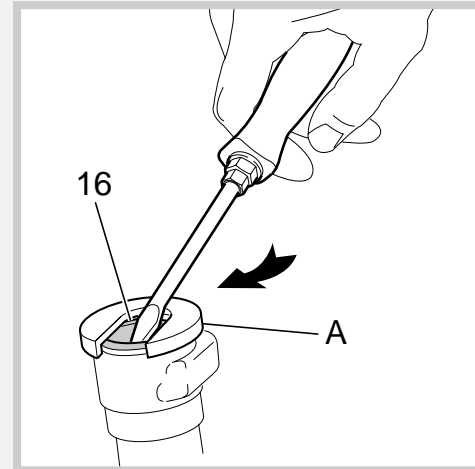

**FIG. 13**

Remove the upper washer (17) from the slider.

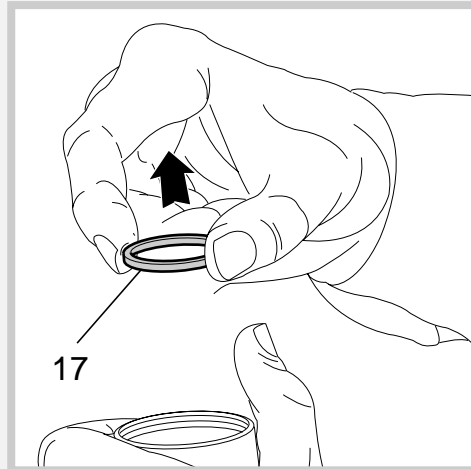

**FIG. 14**

To remove the guide bushing (18), beat powerfully the slider edge on a wooden surface. Perform this operation with extreme care and try to keep the slider perpendicular to the wooden surface.

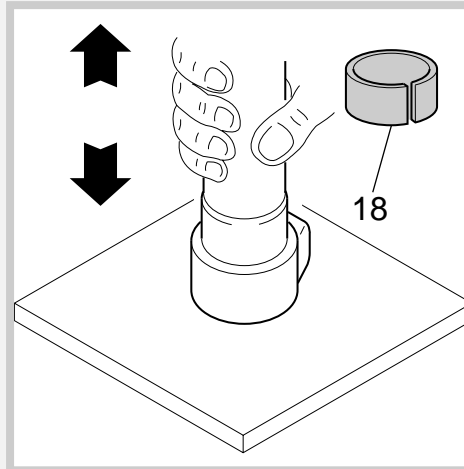

## REASSEMBLY

**CAUTION:** before reassembling, all metal components should be washed carefully with inflammable and biodegradable solvent and dried with compressed air.

**FIG. 15**

Fit the sleeve (33), with its completely open side facing outwards, on the stanchion edge (13). Fit the outer snap ring (32). Make sure it is fully seated in the tube.

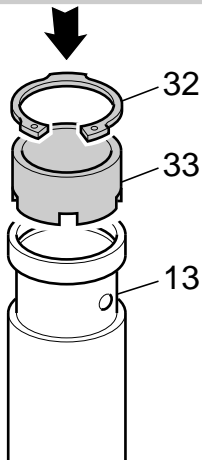

**FIG. 16**

Stick some adhesive tape onto the stanchion bottom (13) to protect it. Insert the oil seal (16), duly lubricated, the bushing washer (17) and the slider guide bushing (18) into the stanchion. Remove the adhesive tape and clean the stanchion.

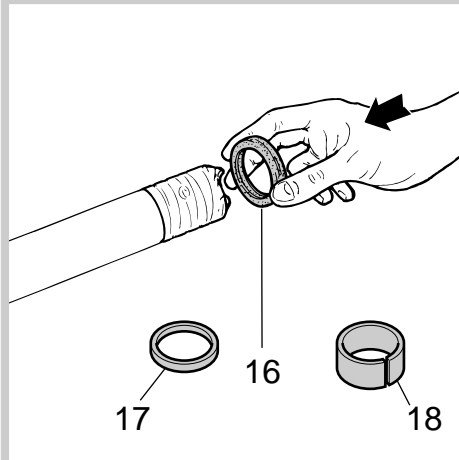

**FIG. 17**

Insert the bit of the flat screwdriver into the guide bushing slot (34) to fit it on the stanchion tube. Ease it into the tube seat by hand.

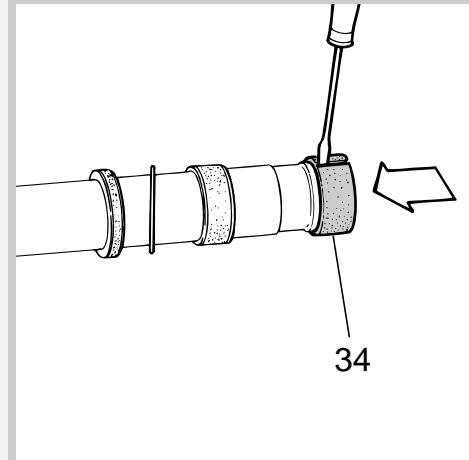

**FIG. 18**

Gently insert the stanchion tube (13) into the slider from the bushing side.  
Fit the guide bushing (18) and the bushing washer (17) into the slider seat by hand.

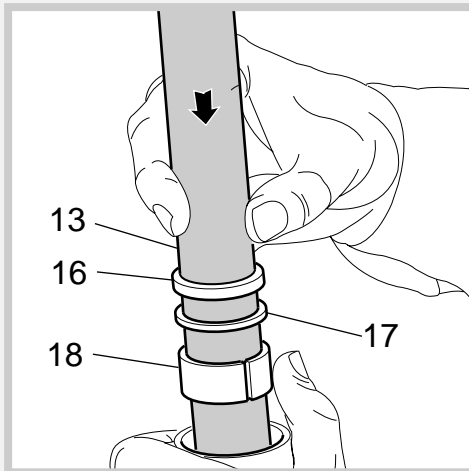

**FIG. 19**

Press the oil seal (16) into place until it touches the lower washer (17) by using the seal press (B).

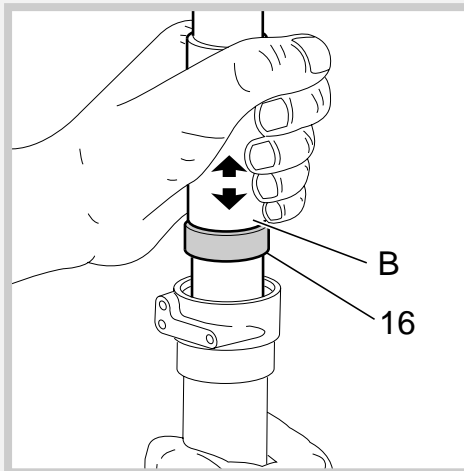

**FIG. 20**

Insert the stop ring (15) making sure it is properly seated into place.  
Use buffer (B) to properly seat the ring into the slider.

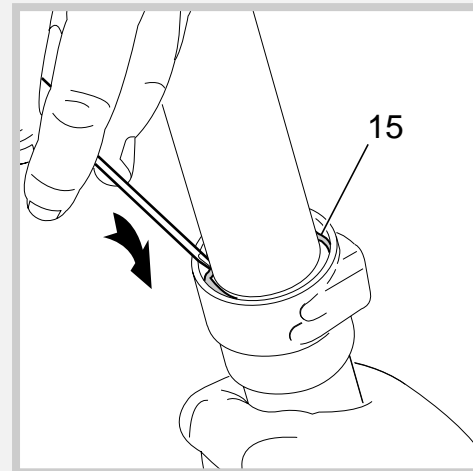

**FIG. 21**

Lubricate the dust seal **(14)** and insert it into the top of the slider.  
Fit it into the slider seat.

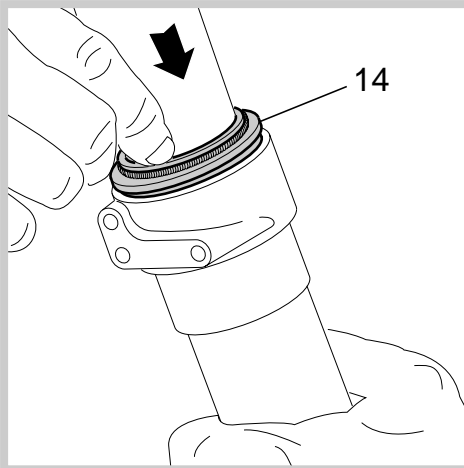

**HYDRAULIC CARTRIDGE**

**FIG. 22**

Fit the rebound spring **(12)** and the lower washer **(8A)** into the hydraulic cartridge.  
Insert the complete hydraulic cartridge **(11)** with the stanchion tube pressed fully down.

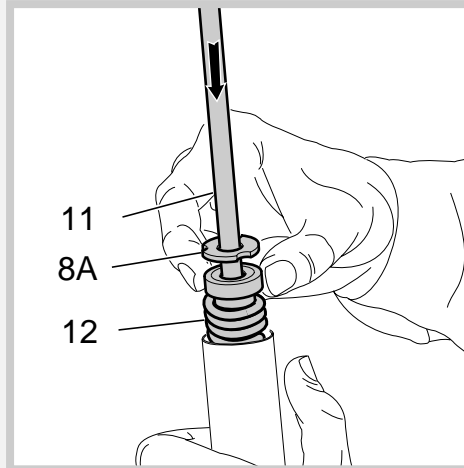

**FIG. 23**

Grease the O-ring **(21)** on the foot nut **(22)** and screw the nut onto the hydraulic cartridge thread.  
Tighten to 12 Nm.  
Pump stanchion up and down several times to make sure it slides properly through the stroke.

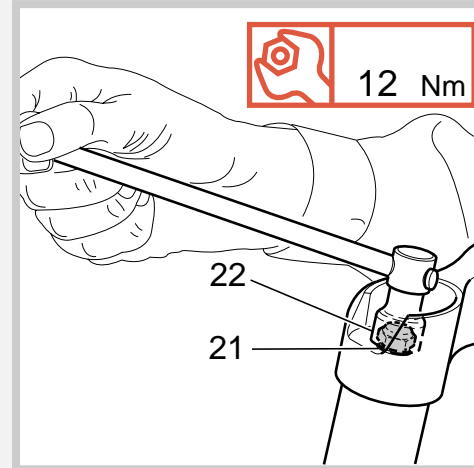

### HOW TO FILL WITH OIL

**FIG. 24**

Pour the oil little by little when the stanchion tube is fully down and then pump the cartridge rod (11) up and down so as to have a better filling. Cartridge is full when no air is detected when pumping, in the fully compressed position. Check that oil level is 100 mm from the top of the stanchion tube in each leg.

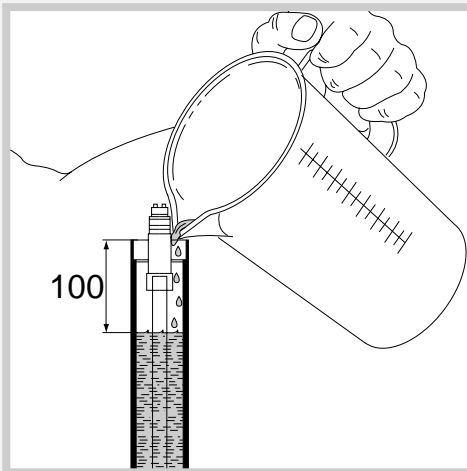

### SPRING AND CAP

**FIG. 25**

Fit the spring (9), the preload sleeve (1) and the upper washer (8) into the stanchion tube. Lubricate the O-ring (10) on the top of the preload knob support and the O-ring (6) on the cap (5).

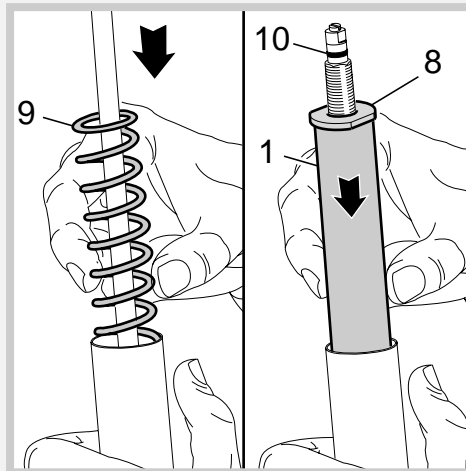

**FIG. 26**

Position the plunger (7, see exploded view), into the cap, to the minimum preload value. Screw the complete plug (5) fully onto the cartridge rod (11).

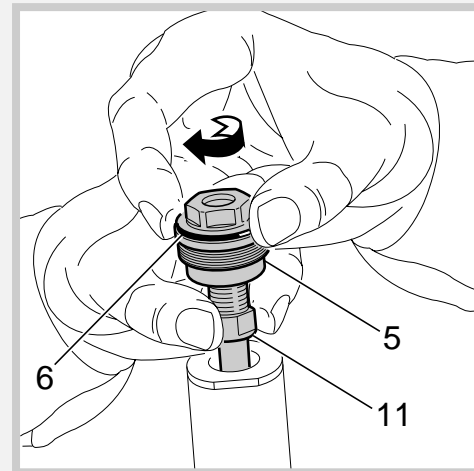

**FIG. 27**

Lift the stanchion tube and fit the plug (5) by hand. Place the stanchion tube in vice. Make sure not to damage or squeeze it. Tighten to 12 Nm.

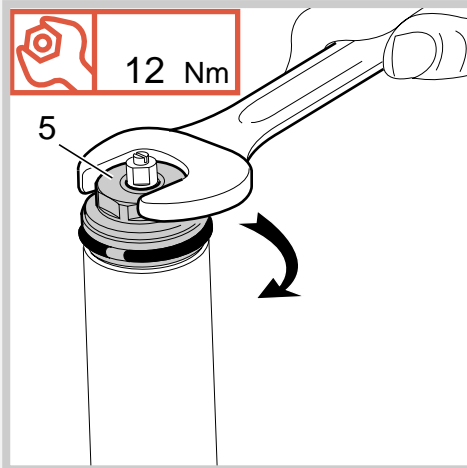

**FIG. 28**

Fit the stop ring (4) of the preload knob support and make sure it is fitted properly into its seat.

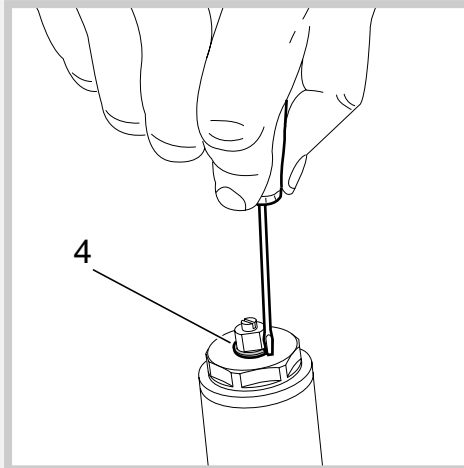

**FIG. 29**

Fit the preload knob (2), secure it on the support and tighten the Allen bolt (3) to 1.5 Nm.  
Fit the brake arch to the fork leg, and then install fork legs into crown and upper crown as specified in section "INSTALLATION".

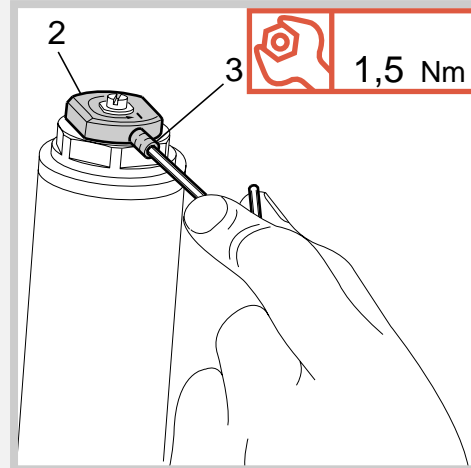

### **SPECIFIC MARZOCCHI TOOLS**

Ref.	Item.	Description and use
A	536064 GG	Slider protector: to remove oil seal from the slider
B	R 5083 AC	Oil seal press: to press oil seal into the slider

